

Model: VHYD-01 Hydraulically Operated Diaphragm Type Dosing Pumps

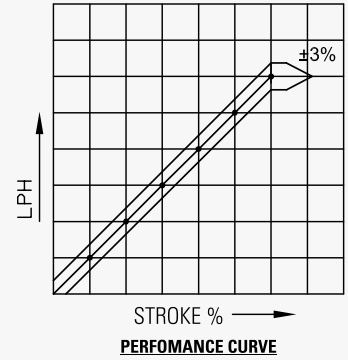

SELECTION CHART

RATIO 15:1 MOTOR 1500 RPM				PL. Dia mm	Max. Pr. Kg/cm ²	RATIO 8:1 MOTOR 1500 RPM			
Cap LPH	Suc. Del. mm NB/BSP	% OF Max. Pr.	Motor K.W.			Cap LPH	Suc. Del. mm NB/BSP	% OF Max. Pr.	Motor K.W.
1.5	15	ALL	0.37	6	80	2.8	15	ALL	0.37
2.8	15			8	80	5	15		
4.2	15			10	80	7.8	15		
6.1	15			12	80	11.3	15		
11	15			16	80	20	15		
17	15		20	60	31	15	0.75		
24	15		24	42	45	15			
48	15		32	24	80	15			
68	15		40	15	125	15			
82	15		44	12	152	15			

MOC CHART

Sr. No.	Description	MOC	Sr. No.	Description	MOC
01	PLUNGER	EN 8	4	NRV Sealing Ring	PTFE
02	Liquid Head	SS304, SS316, alloy20, P.P, PVC, PTFE			
03	Non Return	SS304, SS316, alloy20, P.P, PVC, PTFE	5	NRV Balls	SS,PTFE, Glass, Ceramic

FEATURE

- Multiple head pumps with common drive for mixing two or more liquid in a desired ratio. The ratio can be easily reset

DIMENSIONS IN mm

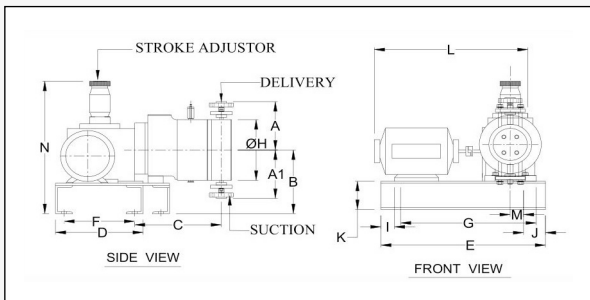

A	A1	B	C	D	E	F	
130	130	180	250	200	340	170	
G	H	I	J	K	L	M	N
330	150	10	15	75	400	30	350

WEIGHT (App) : 50 Kg
PACKING SIZE : 19X19X16 Inches